

# MOBILITY DOCK

ITEM NO.: 5555925006 | MODE 2 CHARGER, 6A, 1-PHASE, TYPE K  
FOR CHARGING ELECTRIC AND HYBRID CARS

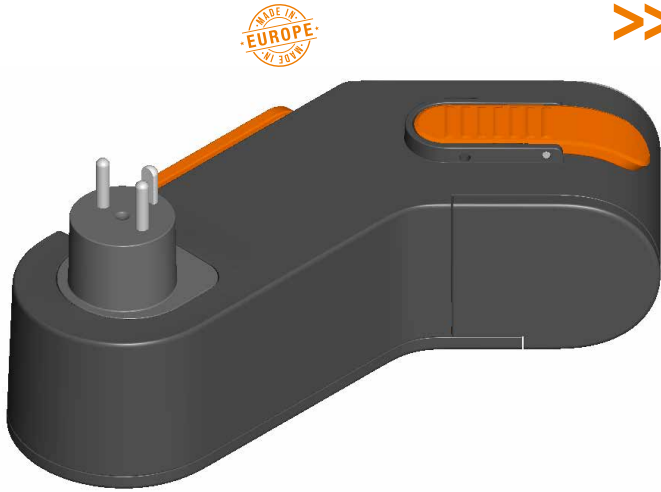

**>> THE MOBILITY DOCK, 6A, 1-PHASE MODE 2 CHARGER FROM LAPP** is a mobile charging device specially designed for charging at home and on the road. Connected to a standard household socket type K, it enables electric and plug-in hybrid cars to be charged easily and safely anywhere. The existing mode 3 charging cable is effortlessly connected between the car and the MOBILITY DOCK, which is then connected to the mains power. As well as the actual charging process, the MOBILITY DOCK has a range of protection functions, including essential overcurrent and excess temperature monitoring and protection for the user.

## ADVANTAGES AT A GLANCE

- Mobile charging device for use with a standard domestic power socket type K (country: Denmark)
- 100% user friendly and intuitive
- Unique and elegant, never gets dirty
- Compact design and ergonomic, easy handling
- Space saving storage in boot
- Charging process starts automatically when requested by the car
- Meets all relevant requirements of the product standard IEC62752
- Protection rating IP44

## TECHNICAL INFORMATION

- Mode 2 charging mode in compliance with IEC 61851
- In-cable control and protection device in compliance with IEC 62752
- CE-compliant - meets all stipulations of the applicable standards
- Type K power connector (charging current 6A 1-phase)
- Socket for mode 3 charging cable (IEC 62196)
- Protection rating IP44 (connected IP44)
- Charging power up to 1.4kW, automatically adjusting
- Weight 750g
- Dimensions (H x W x D): 255mm x 135mm x 106mm
- Ambient temperature -25 °C to +45 °C

## INCLUDED IN DELIVERY

- Charger with type 2 coupling and type K power connector including dust cap
- Operating instructions

## KEY FEATURES

- Socket distance support lever
- Release lever for easy disconnection
- Use with the mode 3 charging cable already available in the car
- Gyro sensor for vertical position monitoring
- LED display in housing

## SAFETY FUNCTIONS

- Self-test on start
- Residual current detection (DC) - provides effective protection against DC faults, so that upstream type A RCDs do not become blind
- Residual current detection (AC) - immediately disconnects in the event of potentially fatal AC faults
- Charge monitoring to vehicle
- Continuous protective earth
- Relay monitoring
- Overcurrent detection
- Over and undervoltage detection
- Electronics and power connector - Safe charging thanks to fully automatic regulation of charging power in case of overheating.
- Protection rating IP44 (charger), IP44 (connector/coupling)
- Halogen-free
- Flame-retardant
- Oil-resistant

## ELECTRICAL DATA

- Charging power up to 1.4kW
- Nominal voltage 230V
- Nominal current 6A, 1-phase
- Frequency 50Hz
- Residual current device (RCD) ≤ 30 mA AC, ≤ 6 mA DC